

USING YOUR UNIPHONE 1000™



Ultratec

305-000803

Acknowledgement

In 1963, Dr. Robert H. Weitbrecht, an American physicist who was deaf, developed an acoustic coupler that could send and receive teletypewriter signals over the telephone lines. His invention, the Weitbrecht Modem, enabled people who are deaf to use the telephone for the first time.

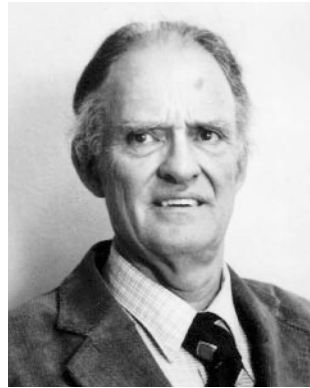

**Dr. Robert H. Weitbrecht,
1920-1983, inventor of the
first text telephone modem.**

While modern technology now makes it possible to build advanced microcomputer devices like your new Ultratec text telephone, the Weitbrecht modem remains the major technological breakthrough that began telecommunications for the deaf. Ultratec wishes to acknowledge the importance of Dr. Weitbrecht's contribution to the welfare of people who are deaf the world over.

Ultratec, Inc.
450 Science Drive
Madison, WI 53711
(608) 238-5400 (Voice/TTY)
Fax: (608) 238-3008
Email: service@ultratec.com
www.ultratec.com

Fourth edition
May 2002

First printing

© 1993-2002 Ultratec, Inc.

Ultratec and *Turbo Code* are registered trademarks of Ultratec, Inc.
Uniphone 1000 and *Auto ID* are trademarks of Ultratec, Inc.

CONTENTS

	Important safety instructions	p. 2
	Overview of the Uniphone 1000	4
	Introduction	p. 5
CHAPTER 1	Setup	p. 7
	Installing a battery	8
	Plugging in power and the telephone line	9
	About Auto ID™	10
	About Turbo Code®	11
	Using Turbo Code interrupt	11
	About the feature keys	12
CHAPTER 2	Calling	p. 15
	Making a voice telephone call	16
	Answering a voice telephone call	16
	Making a TTY call	17
	Answering a TTY call	19
	Using Voice Carry Over (VCO)	20
	About direct VCO	22
	Using Hearing Carry Over (HCO)	23
	Troubleshooting	p. 24
	Specifications	p. 26
	Index	p. 31
	Conversation etiquette	Back cover

Important safety instructions

When using your Uniphone 1000, basic safety precautions should always be followed to reduce the risk of fire, electric shock, and injury to persons.

Save these instructions!

1. Read and understand all instructions.
2. Follow all warnings and instructions on the Uniphone 1000.
3. Unplug the Uniphone 1000 from the wall outlet before cleaning. Do not use liquid or aerosol cleaners. Use a damp cloth for cleaning.
4. Do not use the Uniphone 1000 near water, for example, near a bath tub, wash bowl, kitchen sink, laundry tub, in a wet basement, or near a swimming pool.
5. Do not place the Uniphone 1000 on an unstable cart, stand, or table. The Uniphone 1000 may fall, causing serious damage to the Uniphone 1000.
6. The Uniphone 1000 should be operated only from the type of power source indicated on the marking label. If you are not sure of the type of power supply to your home, consult your dealer or local power company.
7. Do not allow anything to rest on the power cord. Do not locate the Uniphone 1000 where people can walk on the cord.
8. Do not overload wall outlets and extension cords. This overloading can result in a fire or electric shock.
9. To reduce the risk of electric shock, do not disassemble the Uniphone 1000, but take it to a qualified service person when service or repair work is required. Opening or removing covers may expose you to dangerous voltages or other risks. Incorrect re-assembly can cause electric shock when the Uniphone 1000 is subsequently used.
10. Avoid using a telephone (other than a cordless type) during an electrical storm. There is a remote risk of electric shock from lightning.

11. Unplug the Uniphone 1000 from the wall outlet and refer servicing to qualified service personnel under the following conditions:
 - a. When the power supply cord or plug is damaged or frayed.
 - b. If liquid has been spilled into the Uniphone 1000.
 - c. If the Uniphone 1000 has been exposed to rain or water.
 - d. If the Uniphone 1000 does not operate normally by following the operating instructions. Adjust only those controls that are covered by the operating instructions. Improper adjustment of other controls may result in damage and will often require extensive work by a qualified technician to restore the Uniphone 1000 to normal operation.
 - e. If the Uniphone 1000 has been dropped and/or damaged.
 - f. If the Uniphone 1000 exhibits a distinct change in performance.
12. Do not use the Uniphone 1000 to report a gas leak in the vicinity of the leak.
13. Ultratec recommends plugging your Uniphone 1000 into a surge-protected outlet. This will protect the TTY from damage caused by electrical surges due to lightning or other causes.

Battery safety

Caution: To reduce the risk of fire or injury to persons, read and follow these instructions:

1. Use only the type and size battery specified in the battery instructions for your unit.
2. Do not dispose of the batteries in a fire. Cells may explode. Check local codes for possible special disposal instructions.
3. Do not open or mutilate the batteries. Released electrolyte is corrosive and may cause damage to the eyes or skin. It may be toxic if swallowed.
4. Exercise care in handling batteries in order not to short them with conducting materials such as rings, bracelets, and keys. The battery or conductor may overheat and cause burns.

INTRODUCTION

Your new Uniphone 1000™ is both a text telephone* (TTY) and a telephone. It can be used to make telephone calls, TTY calls, or Voice Carry Over (VCO) calls.

For a voice call, pick up the handset and use the Uniphone 1000 like any other telephone.

For a TTY call, press the **On/Off** key and type. To use VCO, pick up the handset at any time during your call.

Other features of the Uniphone 1000 include the following:

Auto ID™ alerting system. Auto ID automatically alerts the answering party that you are calling by TTY.

Battery backup allows you to use the Uniphone 1000 during a power outage. An 9-volt alkaline battery (not included) will power the Uniphone 1000 for 30-45 minutes of normal use during a power outage.

Call progress displays the ringing or busy status of the telephone line.

Feature keys allow you to quickly use the built-in Uniphone 1000 convenience features.

Turbo Code® communication protocol transmits typed characters to other Turbo Code TTYs as fast as you can type. Turbo Code also allows you to interrupt the other person while he or she is typing.

*Please note that in this manual TTY, TDD, and text telephone all refer to the same device.

Overview of the Uniphone 1000

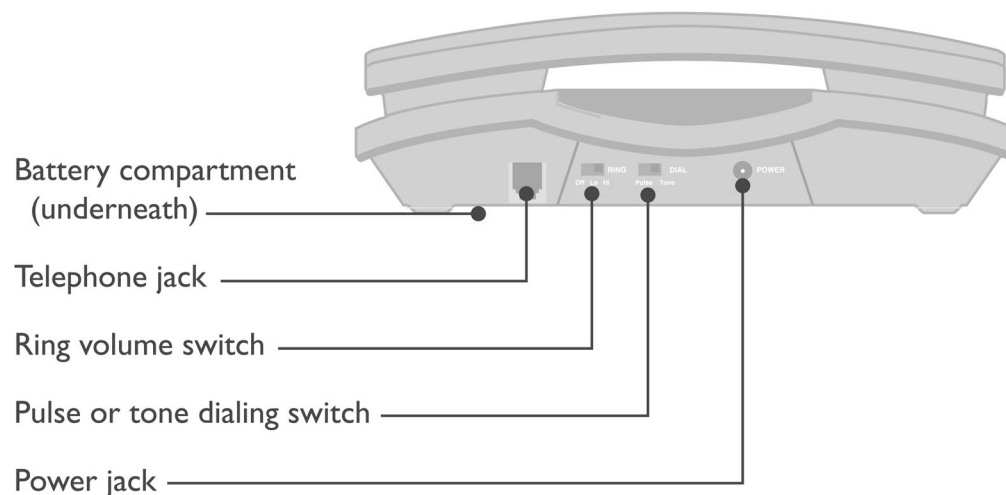
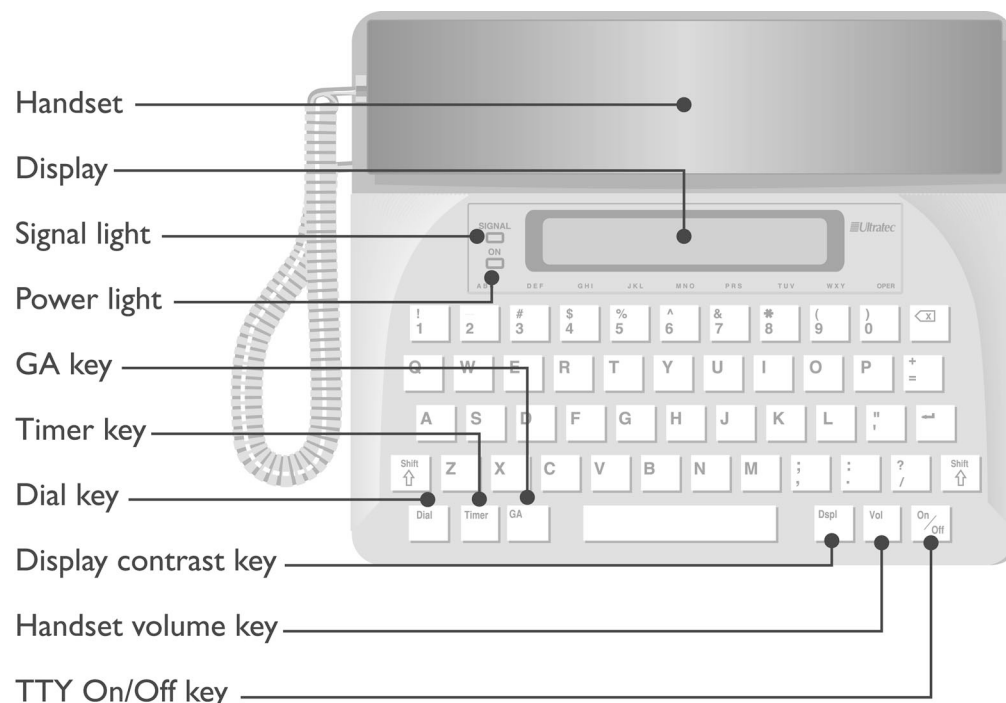



SETUP

All you do to set up the Uniphone 1000 is plug it in! You can also install a 9-Volt alkaline battery (not included) if you want to use the Uniphone 1000 during a power outage.

Be sure to use only the power adapter that comes with the Uniphone 1000.

After opening the box, you should find the following parts:

- Uniphone 1000
- Handset
- Handset cord
- AC adapter
- Telephone line

Installing a battery

Installing a battery (not included) will allow you to use the Uniphone 1000 for 30-45 minutes of normal use during a power outage. Use a 9-volt alkaline battery. The battery compartment is on the bottom of the Uniphone 1000. Follow the steps below to install a battery.

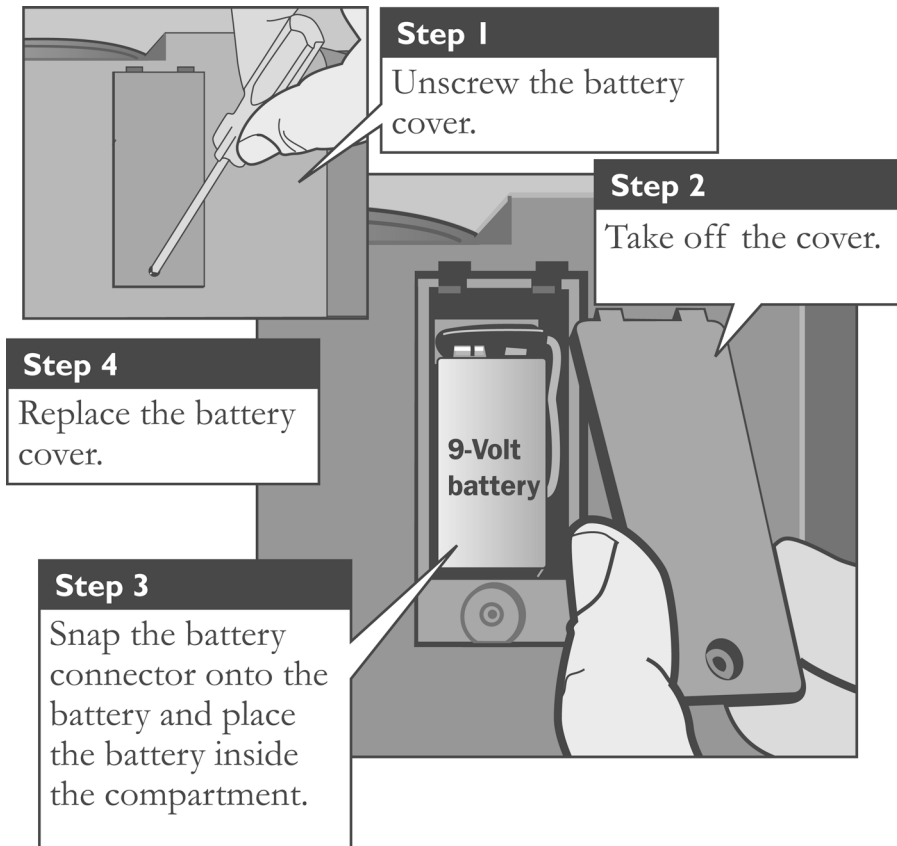

WARNING! Do not burn or puncture the battery. It could release toxic material that could injure you. Do not dispose of the battery in household trash. For information about recycling or proper disposal, consult your local trash collection or disposal organization.

Plugging in power and the telephone line

CAUTION! Do not plug the Uniphone 1000 into any line other than a standard analog telephone line. If you do, you may damage your telephone system or the Uniphone 1000. You will also void your warranty.

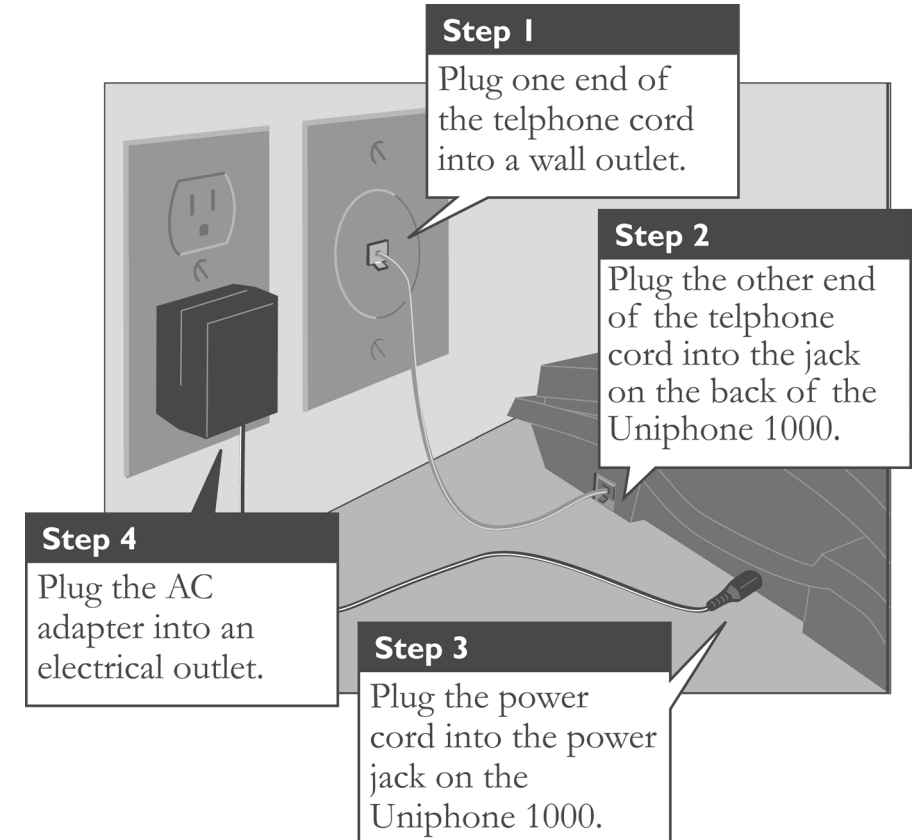

After you plug in the Uniphone 1000, hold down the **[Shift]** key and press the **[On/Off]** key. You will see UNIPHONE on the display:



You will see this display when you are not using the Uniphone 1000. It means the telephone is hung up and TTY mode is off.

What kind of telephone line?

You need a standard analog telephone line with either pulse or tone dialing. If you plan to use the Uniphone 1000 in an office, the telephone line may need modification because many offices have digital telephone systems. Contact your telephone installer to assure that your office telephone system supports a standard telephone line. This line is the same kind of telephone line you need for many fax machines or computer modems.

Connecting a signaler light

If you want to use a signaler light with the Uniphone 1000, plug the signaler light into an unused extension-telephone wall jack. If you have only one jack in your house or office, use a Y-jack (also called a duplex jack) to plug both the Uniphone 1000 and the signaler into the same outlet. You can get a Y-jack at any telephone store.

Setting pulse or tone dialing

The Uniphone 1000 is set to tone dial. If your telephone line uses pulse dialing, set the dial switch on the back of the Uniphone 1000 to PULSE. Contact your telephone company if you are not sure about the dial setting your telephone uses.

About Auto ID™

Auto ID alerts a hearing person or an emergency service such as 911 that you are using a TTY. Auto ID only works in TTY mode. After you dial a number, Auto ID sends several audible tones over the telephone line every few seconds. You will see **SENDING ID** on the display. Auto ID stops sending tones when someone starts typing.

Auto ID will also send tones during a TTY conversation if no typing occurs for a few moments. It will continue sending tones until typing resumes.

Auto ID is not the same as Caller ID, a separate service available through your telephone service provider that requires additional equipment.

About Turbo Code®

Your Uniphone 1000 uses either Turbo Code or Baudot code during a TTY conversation. Turbo Code is an improved version of Baudot code because it sends typed characters to other Turbo Code TTYs as fast as you type. Using Turbo Code allows you to interrupt the other person while he or she is typing.

Turbo Code also allows you to use the special “shift” characters on the top row of your TTY keyboard (**example: @ # % ^ & * _ < >**). If your call is connected in Baudot, these characters cannot be received or printed at the other end of the line. This is yet another example of why Turbo Code is better for TTY communication than Baudot—especially in the day of sharing your email address.

The Uniphone 1000 automatically connects in either Turbo Code or Baudot code depending on what code the other TTY is using.

Using Turbo Code interrupt

When you are connected to another Turbo Code-equipped TTY, you can interrupt the other person while he or she is typing by holding down the **Shift** key and pressing the **I** key. You will see **INTERRUPT REQUESTED** on your display. The other person will see **INTERRUPT** on his or her display. The other person can either choose to stop typing and let you type or ignore your interruption and continue typing.

If you see **INTERRUPT** on your display while you are typing, it means the other person wants to interrupt you and start typing. You can choose to stop and let the other person go ahead or continue typing.

The interrupt feature only works with TTYs that have Turbo Code and only when the other person is typing continuously. If nothing happens when you try to interrupt the other person, the other TTY may not have the interrupt feature or the other person may not be typing continuously.

About the feature keys

The On/Off key

Press the **[On/Off]** key to turn on TTY mode or VCO mode before you make or answer a call. You also use the **[On/Off]** key with the **[Shift]** key to hang up the Uniphone 1000 after a TTY or VCO call. To hang up, hold down the **[Shift]** key and press the **[On/Off]** key. If you see SHIFT+ON TO HANG UP on the display screen, make sure you press and hold the **[Shift]** key while you press the **[On/Off]** key.

The Dial key

Press the **[Dial]** key to dial a telephone number before a TTY or VCO call. After you press the **[Dial]** key, you will see DIAL: on the left side of the display. Use the number keys to dial.

You do not need to press the **[Dial]** key to dial a telephone number for a voice call.

The Volume key (amplification)

Press the **[Vol]** key to increase the Uniphone 1000 handset volume during a voice or Hearing Carry Over (HCO) call. After you press the **[Vol]** key, you will see VOLUME 2 on the display. Each time you press the **[Vol]** key the handset volume will increase until you reach the VOLUME MAX setting. After you reach the maximum volume setting, the handset returns to the VOLUME MIN setting. The handset volume returns to the minimum volume setting after you hang up the Uniphone 1000.

The Timer key

Press the **[Timer]** key when you want to see the amount of elapsed time since your TTY or VCO call began. You will see TIMER: on the display and the number of minutes and seconds you have been using the Uniphone 1000 for the call. The timer will stay on the display until you press a key or the other person starts typing.

Note: During a voice call, the timer appears on the display throughout the conversation.

The Display key

Press the **[Dspl]** key to adjust the display screen contrast. There are eight contrast settings to choose from. The display screen contrast remains set to the setting that you select until you change it again.

The GA key

Press the **[GA]** key, in TTY mode, when you finish typing a line and you want the other person to start typing. GA is use frequently during a TTY conversation. The **[GA]** key is for your convenience. If you wish, you may simply type GA to let the other person know you want them to type. GA is a TTY abbreviation for “go ahead.” For more TTY abbreviations, see the back cover of this manual.

2 CALLING



There are two ways to call someone with the Uniphone 1000. You can call by voice telephone or by text telephone (TTY). A voice call using the Uniphone 1000 is the same as with any telephone: pick up the handset, dial, and listen for a ring or busy signal. A TTY call is the same as with any TTY—turn on the TTY, dial a telephone number, and wait to read a response on the display.

Making a voice telephone call

1. Pick up the handset.
2. Dial the telephone number using the number keys.
3. Go ahead with the conversation.
4. Hang up the handset when you are finished.

Answering a voice telephone call

1. The telephone will ring when someone calls. (If a signal light is connected, the light will flash.)
2. Pick up the handset.
3. Go ahead with the conversation.
4. Hang up the handset when you are finished.

Making a TTY call

1. Press the **On/Off** key and then press the **Dial** key. Both the signal and power lights will turn on.

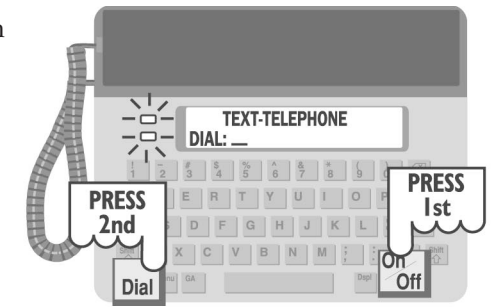

2. Type the telephone number. The Uniphone 1000 dials as you type. If you make a mistake while dialing, hang up (hold down the **Shift** key and press the **On/Off** key) and go to step 1.

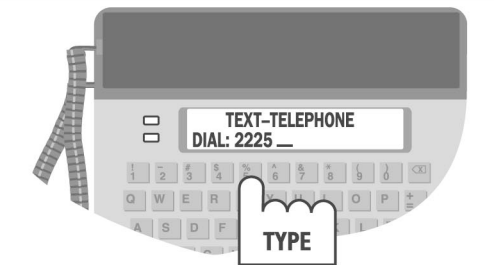

3. Watch the display and signal light for a ring signal. When you see an answer on the display, type a greeting.



4. When your call is finished, hold down either **Shift** key and press the **On/Off** key to hang up.

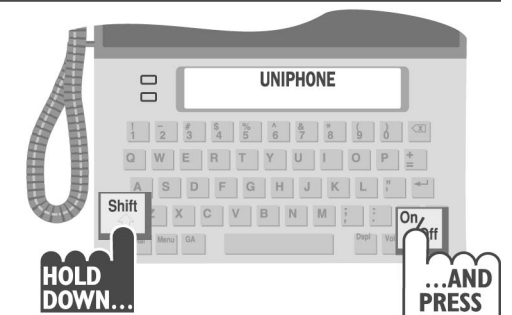

Call progress

The signal light and display show you what is happening on the telephone line in the following ways:

Signal light	Display	Telephone line
Stays on		dial tone
Slow flashing	RING	ringing
Quick flashing	BUSY	busy
Flickering		other person picking up handset or speaking

Dialing tips

- In an office, use a 9 and other numbers for an outside line. The exact method of dialing will depend on your telephone system. Dialing with a TTY should be the same as dialing a voice call.
- For long distance, include a 1 and the area code.
- Use a ! for a hook flash. A hook flash is sometimes used in a voice mail system or to transfer a call.
- You cannot use * and # with pulse dialing.

Answering a TTY call

1. The Uniphone 1000 will ring notifying you of an incoming call. (If a signal light is connected, the light will flash.)

2. Turn on the Uniphone 1000.

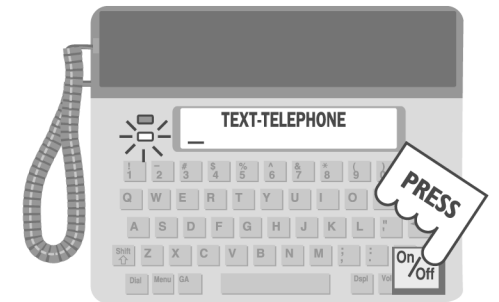

3. Type a greeting.

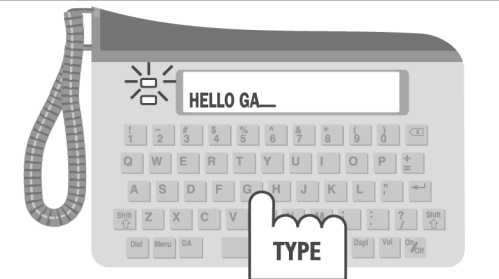

4. When you are finished with your conversation, hold down either **Shift** key and press the **On/Off** key to hang up.

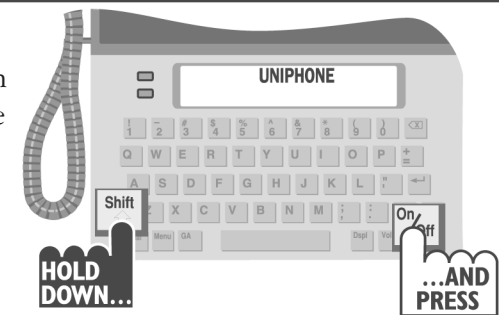

Using Voice Carry Over (VCO)

People who cannot hear but wish to speak for themselves can make Voice Carry Over (VCO) calls. A VCO call is a combination voice call and TTY call—you speak and read responses and the other person listens and types. The Uniphone 1000 is ideal for VCO calling because it is a combination voice telephone and TTY.

VCO calls can also be made through a toll-free relay service. When you use a relay service, the Communication Assistant (CA) types spoken replies that you can read on your display.

If you do not know the number of your relay service, look in the telephone book.

Note: The Uniphone 1000 cannot translate incoming voice messages into text by itself.

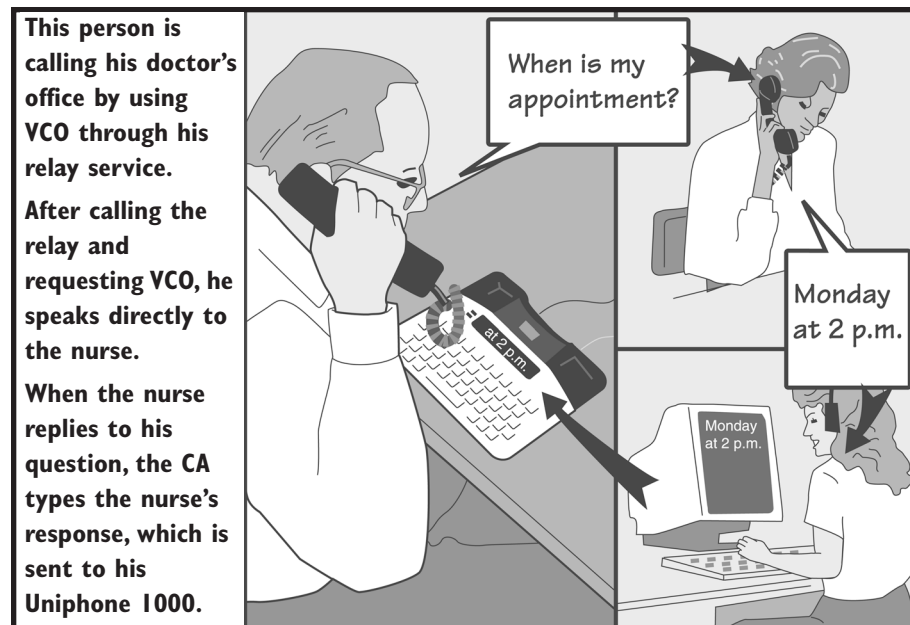

Making a VCO call through a relay service

1. Press the **On/Off** key and then press the **Dial** key. You will see the following display screen:



2. Dial the relay number.
3. When the Communication Assistant (CA) answers, type a request for VCO. For example, VCO PLEASE GA. The CA will notify you when VCO is on.
4. Pick up the handset and tell the CA the name and telephone number of the person you want to call. You will see TEXT TELEPHONE-VCO on the display.
5. The CA dials the number. Watch the display and wait until the CA tells you the call is connected.
6. Begin speaking to the person you are calling.
7. When the other person answers, read his or her response on the display. (The CA types the response.)
8. When you see GA at the end of the line, begin speaking again. Continue speaking and reading until the conversation is finished.
9. When you are finished with your conversation, replace the handset and hang up the Uniphone 1000 by pressing the **Shift** key and the **On/Off** key at the same time.

You do not have to put down the handset each time you finish speaking. The Uniphone 1000 automatically turns off the handset during TTY reception.

About direct VCO

A direct VCO call means that you speak to the other person and he or she types responses back to you. You do not use a relay service for a direct VCO call. The person you call must have a TTY available in order for direct VCO to work.

Making a direct VCO call

1. Press the **On/Off** key and then press the **Dial** key.
2. Dial the telephone number you want to call.
3. Watch the display for a greeting.
4. Type a message saying that you want to use VCO.
5. Pick up the handset and begin speaking.
6. When you finish speaking, watch the display to read the other person's response. Continue speaking and reading until your conversation is finished.
7. When you are finished with the conversation, replace the handset and hang up the Uniphone 1000 by pressing the **Shift** key and the **On/Off** key at the same time.

Answering a direct VCO call

1. The Uniphone 1000 will ring. (If a signal light is connected, the light will flash.) Press the **On/Off** key and type a greeting.
2. Watch the display for a response.
3. After VCO is requested, pick up the handset to either speak or listen to the other person.
4. Speak and read or listen and type responses to the other person.
5. When you are finished with your conversation, replace the handset and hang up the Uniphone 1000 by pressing the **Shift** key and the **On/Off** key at the same time.

Using Hearing Carry Over (HCO)

For people who can hear but are speech impaired, the Uniphone 1000 can be used to make Hearing Carry Over (HCO) calls. HCO is the opposite of VCO. The caller types to the other person (or relay service CA) and listens to the other person's reply.

Making an HCO call

1. Press the **On/Off** key and then press the **Dial** key. You will see the following display screen:



2. Dial the telephone number.
3. Pick up the handset and listen for a response. You will see TEXT-TELEPHONE VCO on the display screen.
4. After someone answers, type a greeting.
5. Continue to listen and type until your conversation is finished.
6. When you are finished with your conversation, replace the handset and hang up the Uniphone 1000 by pressing the **Shift** key and the **On/Off** key at the same time.

You do not have to put down the handset when you want to type. The Uniphone 1000 automatically turns off the handset while you type.

TROUBLESHOOTING

Dialing does not work.

Make sure you have the correct dial setting (pulse or tone) selected for your Uniphone 1000. Make sure you are plugged into a working analog telephone line and that the telephone line is plugged into a wall jack.

The display shows all numbers and punctuation marks instead of words.

Press the spacebar. The text should change to words.

The Uniphone 1000 does not turn on when I press the **On/Off** key even when the AC adapter is plugged in.

Be sure the adapter is firmly plugged in and the electrical outlet is working. If this does not solve the problem, the AC adapter or the Uniphone 1000 may have a problem. Contact your dealer or Ultratec.

The display on my Uniphone 1000 is blank when the AC adapter is plugged in.

Try holding down the **Shift** key while pressing the **On/Off** key. You must do this to turn on the display the first time you plug in the Uniphone 1000. You also have to press those keys after a power outage if you have not installed a battery.

The Uniphone 1000 works fine in the evening, but does not work during the day.

You may have plugged the AC adapter into a switch controlled outlet or electrical power strip. Make sure the switch or power strip is turned on.

My Uniphone 1000 does not ring when I get a call.

Be sure the ringer switch on the back of the Uniphone 1000 is set to ON. Make sure that the unit is plugged into a working telephone line.

Some characters are not being sent.

Because Baudot code does not support special characters, it does not recognize some of the “shift” characters on the top row of a TTY keyboard (**example: @ # \$ % ^ & * _ < >**). To type these characters (such as in an email address) make sure your call is connected in Turbo Code (see *About Turbo Code*® on page 11).

Repair

If your Uniphone 1000 is not working, we may be able to help you solve the problem over the telephone. Call the Ultratec Customer Service Department at (608) 238-5400.

Sending the Uniphone 1000 for repair

If you need to send the Uniphone 1000 to our repair center do the following:

1. Pack it in the original shipping carton or a similar sturdy box.
2. Include a note that describes the problem you are having. The note will help the technicians find the problem. Include a daytime telephone number where you can be reached.
3. Insure the Uniphone 1000 for shipment. Ultratec or an authorized Ultratec Repair Center is not responsible for damage during shipping to our service center.
4. Send the Uniphone 1000 to the following address:

Ultratec National Service Center
450 Science Drive
Madison, WI 53719
(608) 238-5400 (Voice/TTY)
(608) 238-3008 (fax)

SPECIFICATIONS

Physical Dimensions

Size: 8.6" x 7.1" x 2.5"

Weight: 1 lb., 12.5 oz. with battery

Power

AC adapter: 9VDC, 200 ma (barrel is positive)

Adapter is UL/CSA listed

9V battery backup for emergencies

Keyboard

52 easy-touch keys in 5 rows

Display

2-line LCD (2 x 24)

Contrast control

Direct Connect

Plugs into standard (analog) telephone line

Pulse or tone keyboard dialing

Communication Codes

Automatic code detection on incoming and outgoing calls (Turbo Code or Baudot code)

Baudot code:

45.5 baud

Sensitivity: -45 dbm

Output: -10 dbm

Turbo Code:

100 baud (average)

7 data bits

Approvals

FCC approved.

FCC Registration No. (Part 68):

D8KUSA-75135-DT-E

REN: 2.3B

CSA approved.

FCC information

The Uniphone 1000 has been tested and found to comply with the specifications for a Class B digital device pursuant to Part 15 of the FCC Rules. These limits are designed to provide reasonable protection against harmful interference in a residential installation. This equipment generates and uses radio frequency energy and if not installed and used in accordance with the instructions, may cause harmful interference to radio communications. However, there is no guarantee that interference will not occur in a particular installation. If this equipment does cause harmful interference to radio or television reception, which can be determined by turning the equipment off and on, the user is encouraged to try to correct the interference by one or more of the following measures:

- Reorient or relocate the receiving antenna.
- Increase the separation between the Uniphone 1000 and the receiver.
- Connect the Uniphone 1000 to an outlet on a circuit different from that to which the receiver is connected.
- Consult the dealer or an experienced radio/TV technician for help.

This equipment complies with Part 68 of the FCC rules and the requirements adopted by the ACTA. A label is located on the underside of the Uniphone 1000 containing, among other information, an FCC registration number, D8KUSA-75135-DT-E. If requested, this number must be provided to the telephone company.

A plug and jack used to connect this equipment to the premises wiring and telephone network must comply with the applicable FCC Part 68 rules and requirements adopted by the ACTA. A compliant telephone cord and modular plug is provided with this product. It is designed to be connected to a compatible modular jack that is also compliant. See installation instructions for details.

The REN is used to determine the quantity of devices which may be connected to the telephone line. Excessive RENs on the line may result in the devices not ringing in response to an incoming call. In most, but not all, areas the sum of RENs should not exceed five (5.0). To be certain of the number of

devices that may be connected to a line, as determined by the total RENs, contact the local telephone company. The REN for this product is 2.3B.

Should you experience trouble with this telephone equipment, please contact:

Ultratec National Service Center
5901 Research Park Blvd.
Madison, WI 53719
email: service@ultratec.com

For repair or warranty information, please contact Ultratec Inc. Customer Service at (608) 238-5400 (V/TTY). If the equipment is causing harm to the telephone network, the telephone company may request that you disconnect the equipment until the problem is resolved.

This equipment cannot be used on public coin phone service provided by the telephone company. Connection to party line service is subject to state tariffs.

If the Uniphone 1000 causes harm to the telephone network, the telephone company will notify you in advance that temporary discontinuance of service may be required. But, if advance notice is not practical, the telephone company will notify you as soon as possible. Also, you will be advised of your right to file a complaint with the FCC if you believe it is necessary.

Occasionally, your telephone company may make changes in its facilities, equipment, operation, or procedures that could affect the operation of your equipment. If so, you will be given advance notice of the change to give you an opportunity to maintain uninterrupted service.

If your home has specially wired alarm equipment connected to the telephone line, ensure the installation of the Uniphone 1000 does not disable it. If you have questions about what will disable alarm equipment, consult your telephone company or a qualified installer.

Other than replacing the batteries, the Uniphone 1000 does not have any user-serviceable parts. Modification or changes to the Uniphone 1000 not expressly approved by Ultratec, Inc. can void your authority to operate the TTY.

Industry Canada information

NOTICE: This equipment meets the applicable Industry Canada Terminal Equipment Technical Specifications. This is confirmed by the registration number. The abbreviation, IC, before the registration number signifies that registration was performed based on a Declaration of Conformity indicating that Industry Canada technical specifications were met. It does not imply that Industry Canada approved the equipment.

NOTICE: The Ringer Equivalence Number (REN) for this terminal equipment is 0.5B. The REN assigned to each terminal equipment provides an indication of the maximum number of terminals allowed to be connected to a telephone interface. The termination on an interface may consist of any combination of devices subject only to the requirement that the sum of the Ringer Equivalence Numbers of all the devices does not exceed five.

INDEX

A

Abbreviations, *back cover*
AC adapter, 9, 24, 26
Amplification, 12
Auto ID, 5, 10

B

Battery,
 compartment, 4
 disposal, 3, 8
 how long it lasts, 5, 8
 installing a, 8
 safety, 3
 type, 3, 5, 7-8
Baudot code 26

C

Call progress, 5, 18
Calling, 15-23
Calling,
 answering a direct VCO call,
 22
 answering a TTY call, 19
 answering a voice telephone
 call, 16
 call progress, 18
 Hearing Carry Over (HCO),
 23
 making a direct VCO call,
 22
 making a TTY call, 17
 making a VCO call through
 a relay service, 21
 making a voice telephone
 call, 16
Cleaning, 2
Communication Assistant
 (CA), 20
Customer Service phone
 number, 25

D

Dial key, 4, 12
Dialing tips, 18
Digital telephone system, 10
Direct VCO, 22

Display contrast key, 4
Display key, 13
Display screen, 4
Duplex jack, 10

F

Feature keys, 12
 Dial key, 12
 Display key, 13
 GAkey, 13
 On/Off key, 12
 Timer key, 13
 Volume key, 12

G

GA key, 4, 13

H

Handset, 4
Handset volume key, 4, 12
Hang up TTY/VCO, how to,
 9, 17, 19
Hearing Carry Over (HCO),
 defined, 23
 making a call, 23
Hook flash, 18

I

Interrupting during a
 conversation, 11

L

Lightning, danger, 3

O

Off-hook light, 4
On/Off key, 4, 12
Overview, 4

P

Parts list, 7
Power jack, 4, 9
Power, plugging in, 9
Pulse or tone dialing switch, 4,
 10, 24
Pulse or tone dialing, setting,
 10

R

Ready screen, 9
Relay, 20
Repair, 25
 shipping address, 25
Ring volume switch, 4

S

Safety instructions, 2-3
SENDING ID, 10
Signal light, 4
Signaler light, 10
Special characters {! " # \$ % ' -
 () *}, 11, 24
Specifications, 26

T

Telephone jack, 4
Telephone line,
 plugging in, 9
 type, 9-10
Timer key, 4, 13
Transfer a call, 18
Troubleshooting, 24-25
TTY etiquette, *back cover*
Turbo Code, 5, 11, 26
 interrupt, 11

V

Voice Carry Over (VCO)
 calling, 20
 answering a direct VCO call,
 22
 making a direct VCO call,
 22
 through a relay service, 21
 defined, 20
Volume key (amplification), 12

Y

Y-jack, 10

Conversation Etiquette

GA When you talk with another person by TTY, you type while the other person reads. When you want the other person to respond, type GA for “Go ahead.”

GA OR SK To say goodbye, type GA OR SK. This gives the other person a chance to say any last words before ending the conversation.

SKSK Type SKSK to end the conversation.

Q Some people prefer to type Q instead of a question mark because it saves time and is easier to type.

You can use punctuation marks such as commas and periods, although many people choose to omit them. You may also abbreviate words, such as:

GA	go ahead	OPR	operator
SK	stop keying	PLS	please
CD	could	Q	question mark
CUL	see you later	R	are
CUZ	because	SHD	should
HD	hold	THX	thanks
MTG	meeting	TMW	tomorrow
NBR	number	U	you
OIC	oh, I see	UR	your